

4

3

2

1

Revised 12/18/2023

Item	Quantity	Name	Part number	Description
1	1	Rear bracket	1401-0401.1	Rear mounting bracket
2	1	Cross Bar 1		Aluminum extrusion 1x2 42.75"
3	1	Cross Bar 2		Aluminum extrusion 1x2 42.625"
4	1	Cross Bar 3		Aluminum extrusion 1x2 42.188"
5	1	Cross Bar 4		Aluminum extrusion 1x2 41.75"
6	1	Cross Bar 5		Aluminum extrusion 1x2 41.00"
7	1	1401-0401.1 Rear bracket	1401-0401.1	Rear Bracket
8	8	Serrated Flange Locknut	ABABA-.6CNWFS	Metric 18-8 Stainless Steel Serrated Flange Locknuts
9	1	1401-0401.7a inside driver rail		
10	1	1401-0401.8a inside passenger rail		
11	2	Finishing plate	1401.0401.9	2 door finishing plate
12	1	Front cover - driver		
13	1	Front cover - passenger		
14	1	Wind Jammer 2.1	1401.0400.b	0.118" Impact Modified Acrylic, transparent, dark smoke
15	13	T-Nut	3382-T-NUT	1/4-20 10 S ECONOMY T-SLOT NUT, END FEED SINGLE (BLK)
16	10	Rubber Sealing Washer	ABABA-25R62WNO/3/32TH	Oil-Resistant Neoprene Rubber Sealing Washer for 1/4" Screw Size, 0.23" ID, 0.625" OD
17	5	Fastener	ABABA-25C62KNCS	1/4-20 x 5/8 BTN SOC CAP SCRW S/S
18	1	3M double side		
19	4	Rubber - Bronco bracket		Rubber sheet 0.063 x 2.0 x 4.5 in.
20	4	Bronco Coupling Nut	90111A332-JN	Bronco Rack front nut (4x per rack) 316 Stainless Steel Coupling Nut-M6x1 Thread turned down 5mm x 7.5mm
21	32	Plastic Washer	90295A450	Nylon Plastic Washer for Number 12 Screw Size, 0.260" ID, 0.688" OD 0.070" thick Black
22	20	Socket button head screw M6x1 x 20	ABABA-.6C20KBCS	Socket button head screw M6x1 x 20 Stainless Steel
23	4	Socket button head screw M6x1 x 30	ABABA-.6C30KBCS	Socket button head screw M6x1 x 30 Stainless Steel
24	4	Socket button head screw M6x1 x 16	ABABA-.6C16KBCS	Socket button head screw M6x1 x 16 Stainless Steel

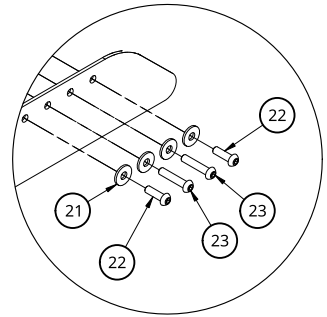
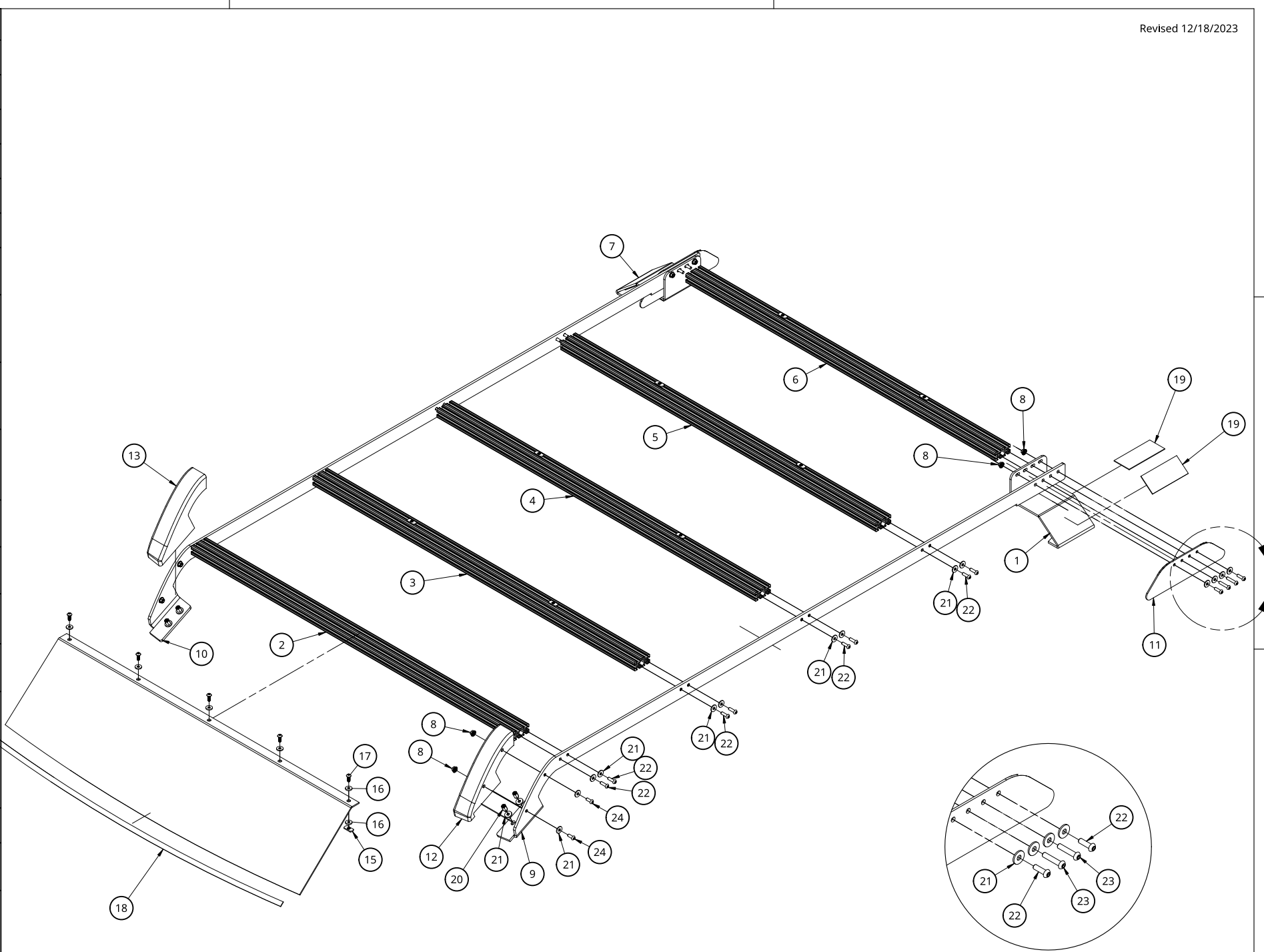

DETAIL A SCALE 1:6



UNLESS OTHERWISE SPECIFIED, DIMENSIONS ARE IN INCHES .XX = ±0- .XXX = ±00- .XXXX = ±000-		NAME	DATE	
ANGULAR = ±° FRACTIONAL = ±	Justus Standley	02/11/2022	TITLE	
SURFACE FINISH ✓	DRAWN		Roof Rack Bronco 2 Door	
DO NOT SCALE DRAWING	CHECKED			
BREAK ALL SHARP EDGES AND REMOVE BURRS	APPROVED		SIZE	DWG NO.
THIRD ANGLE PROJECTION	MATERIAL	FINISH	B	1401-0405
			SCALE	1:10
			WEIGHT	
			SHEET	1 of 1

4

3

2

1

D

D

C

C

B

B

A

A